

- Unpacking 2-2
- Selecting a location 2-2
- Grounding 2-2
- Antenna connection 2-3
- TV jumper cable connection 2-4
- Carrying handle attachment 2-4
- Rack mounting handle detachment 2-4
- Required connections 2-5
 - ◇ Rear panel 2-5
- Advanced connections 2-6
 - ◇ Front panel 2-6
 - ◇ Rear panel—1 2-6
 - ◇ Rear panel—2 2-7
- Tape recorder connections 2-8
 - ◇ Recording from the front panel or rear panel 2-8
 - ◇ Separately recording audio and frequency 2-9
- Monitor display connection 2-10
- Transceive function 2-10
- FSK and AFSK (SSTV) connections 2-11
- Accessory connector information 2-12

 **CAUTION!:** The receiver weighs approx. 20 kg (44 lb). Always have two people available to carry, lift or turn over the receiver.

■ Unpacking

After unpacking, immediately report any damage to the delivering carrier or dealer. Keep the shipping cartons.

For a description and a diagram of accessory equipment included with the IC-R9500, see 'Supplied accessories' on p. iii of this manual.

■ Selecting a location

Select a location for the receiver that allows adequate air circulation and access to the front and rear panels. Do not place in areas subject to extreme heat, cold, or vibrations, or near TV sets, radios and other electromagnetic sources.

■ Grounding

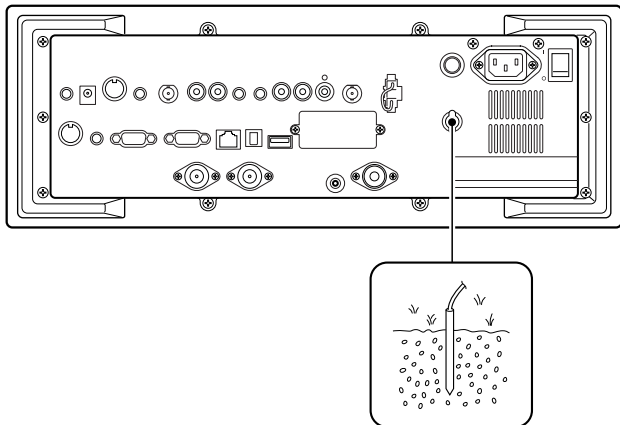

To prevent electrical shock, television interference (TVI), broadcast interference (BCI) and other problems, ground the receiver through the GROUND terminal on the rear panel.

For best results, connect a heavy gauge wire or strap to a long earth-sunk copper rod. Make the distance between the [GND] terminal and ground as short as possible.

⚠ WARNING: NEVER connect the [GND] terminal to a gas or electric pipe, since the connection could cause an explosion or electric shock.

■ Antenna connection

Your antenna plays a very important role in receiver operation. If the antenna is poor, your receiver cannot give you the best performance.

The IC-R9500 requires at least 2 antennas (ANT 1/HF ANT 3, ANT 2) for full coverage from 100 kHz to 3335 MHz. Select an antenna, such as a well matched 50 Ω antenna and feedline. When you wish to use a long wire antenna for short wave bands, use one as long as possible (at least 10 m, 32.8 ft).

CAUTION: Protect your receiver from lightning by using a lightning arrester.

PL-259 CONNECTOR INSTALLATION EXAMPLE

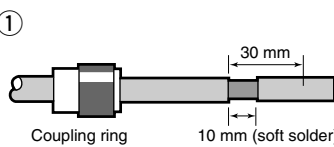
①  Slide the coupling ring down. Strip the cable jacket and tin the braid.

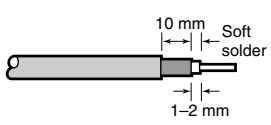
②  Strip the cable as shown at left. Tin the center conductor.

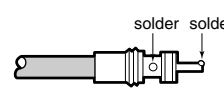
③  Slide the connector body on and solder it.

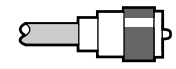
④  Screw the coupling ring onto the connector body.

30 mm ≈ 3/8 in 10 mm ≈ 3/8 in 1-2 mm ≈ 1/16 in

TYPE-N CONNECTOR INSTALLATION EXAMPLE

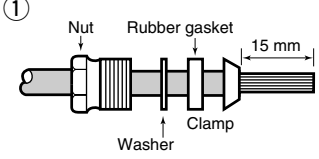
①  Slide the nut, washer, rubber gasket and clamp over the coaxial cable, then cut the end of the cable evenly.

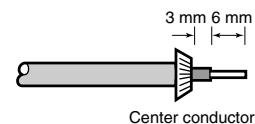
②  Strip the cable and fold the braid back over the clamp.

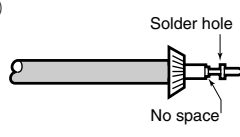
③  Tin the center conductor. Install the center conductor pin and solder it.

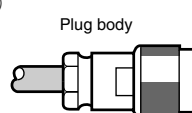
④  Carefully slide the plug body into place aligning the center conductor pin on the cable. Tighten the nut onto the plug body.

- Be sure the center pin is flush with the end of the plug body.

15 mm ≈ 19/32 in 6 mm ≈ 1/4 in 3 mm ≈ 1/8 in

TV jumper cable connection (except for USA version)

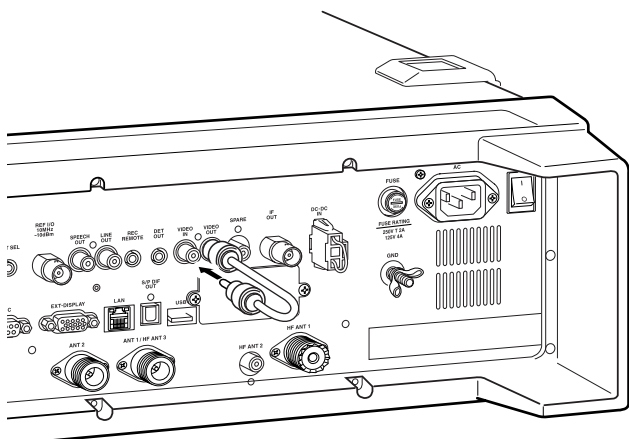

Connect the RCA cable between [VIDEO IN] and [VIDEO OUT].

When connecting external video equipment, connect the unit between [VIDEO IN] and [VIDEO OUT] connectors.

Carrying handle attachment

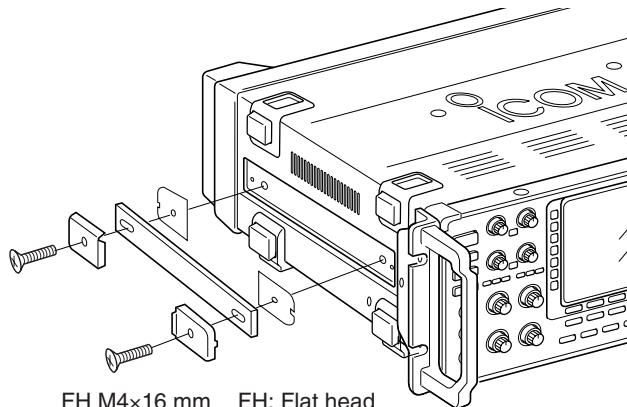

FH M4×16 mm FH: Flat head

- ① Remove the 2 screws from side panel for both side.
- ② Attach the supplied Carrying handles as shown at left.

Rack mounting handle detachment

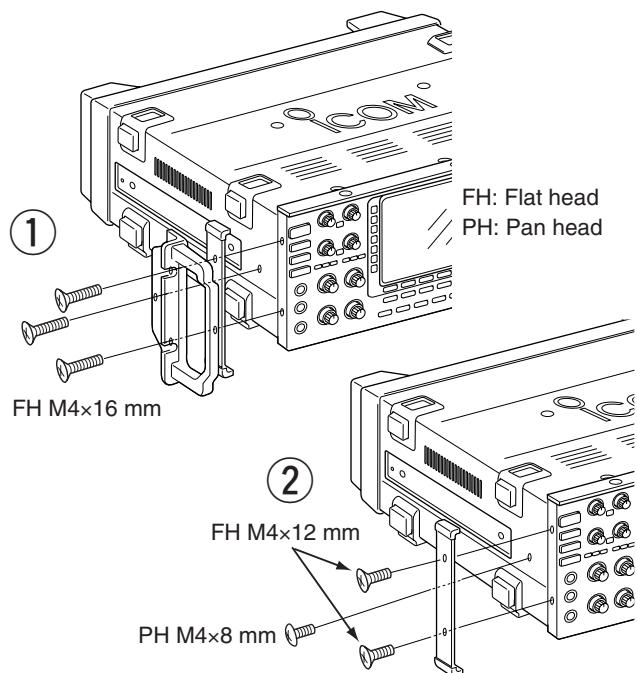

①

FH: Flat head
PH: Pan head

FH M4×16 mm

②

FH M4×12 mm

PH M4×8 mm

When removing the rack mounting handles, use the supplied screws for attach the side plates.

- ① Remove the 6 screws from the rack mounting handles for both side. And remove the rack mounting handles and side plates.
- ② Attach the removed side plates to original position, then tighten the supplied 4 screws (FH M4×12). Tighten the supplied 2 screw (PH M4×8) for hiding screw holes for both side.

CAUTION: NEVER replace the any other than specified screws for side plate attachment or hiding screw holes. If long screw is used, it is caused to damage the receiver's inside board.

Required connections

Rear panel

[VIDEO IN], [VIDEO OUT]

TV jumper cable must be connected when internal TV tuner and LCD are in use (except USA version).
No signals come out from [VIDEO OUT] for USA version.

Ground (p. 2-2)

Ground connection

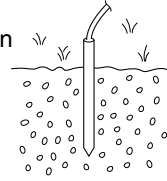

AC outlet

⚠ WARNING:
Use the supplied AC power cable only.

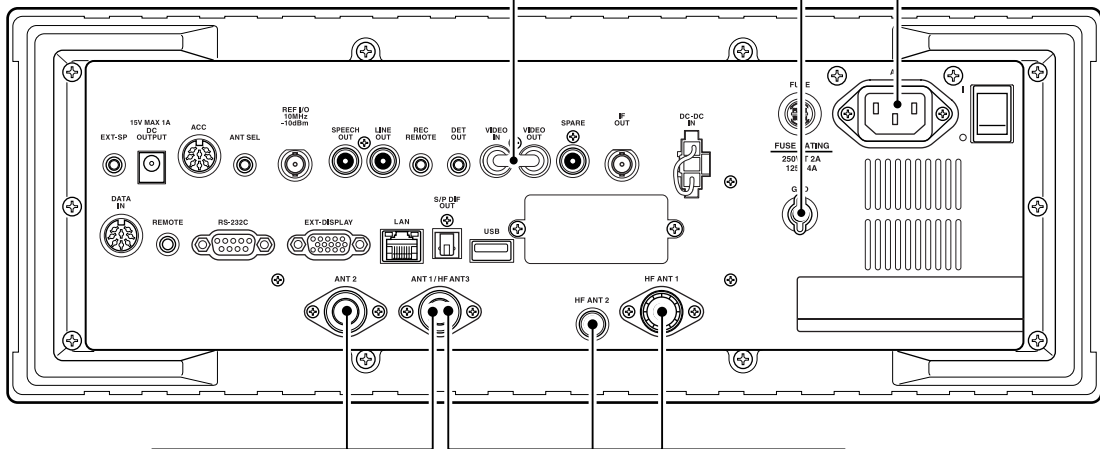

Antenna 1, 2 (p. 2-3)

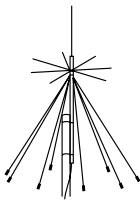

Connects the VHF, UHF wide band antennas.

ANT1: 30–1150 MHz,
ANT2: 1150–3335 MHz

HF Antenna 1, 2, 3 (p. 2-3)

[Example]: HF ANT1 for 3.5, 7 MHz bands, HF ANT 2 for 14, 18 MHz bands, ANT3 for 24, 28 MHz band.

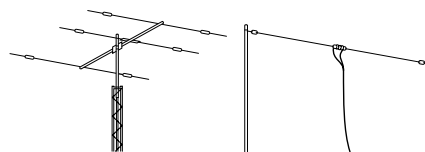

Select the active antenna connector. (p.9-3)

Advanced connections

Front panel

[REC REMOTE], [REC OUT] (p. 2-8)
Connects a tape recorder or other audio equipment.

Headphones
Accepts headphones with 8–16 Ω impedance.

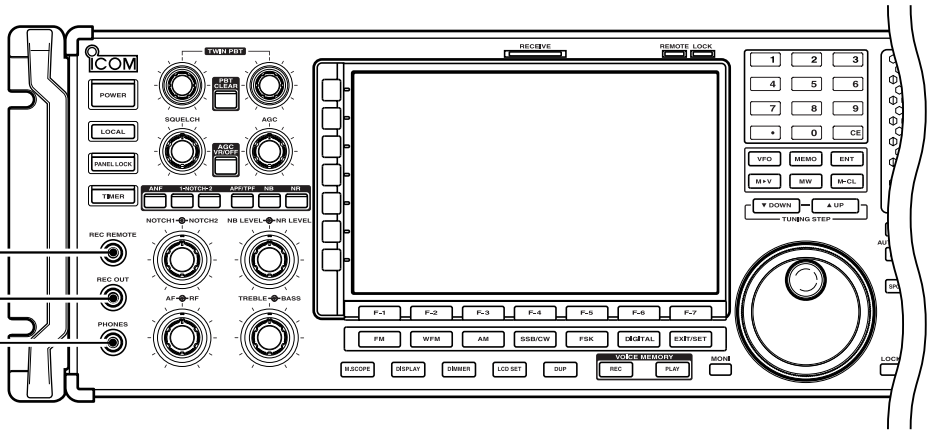

Rear panel—1

External speaker (p. 14-4)

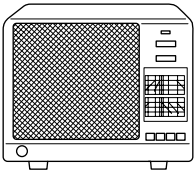

SP-20 (option)

[DC OUTPUT]
Outputs regulated 15 V (approx.) DC for external equipment power supply. (max. 1 A capacity)

[DC-DC IN]
Connects an external power supply (DC 13.5–15 V at least 10 A). Only regulated DC power may be connected.

ACC socket (pgs.2-12)

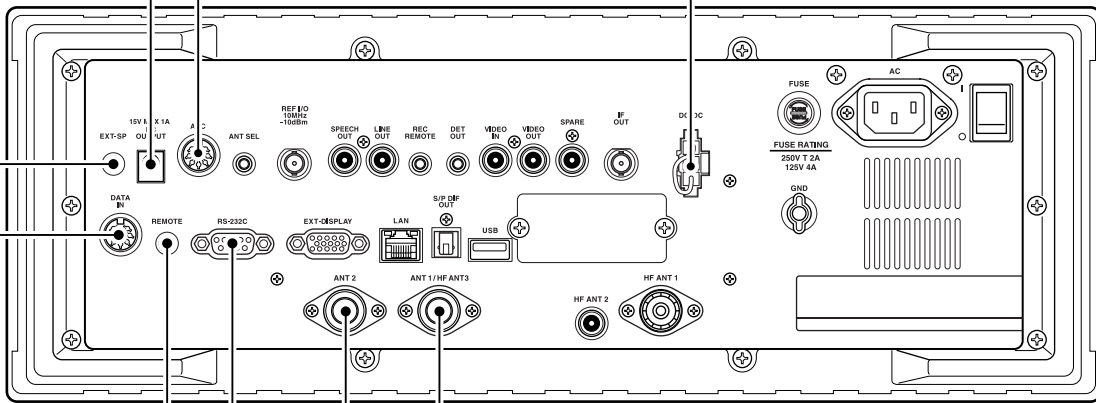

DATA socket (pgs.2-12)

Antenna 1, 2
Connects a pre-amplifier, converter, etc.

[REMOTE], [RS-232C] (p. 13-2)
Used for computer control and transceive operation. The optional CT-17 is required when connecting a PC to [REMOTE].

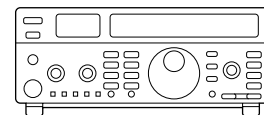
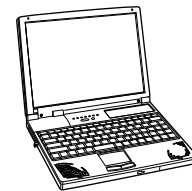

◇ Rear panel—2

[METER]
Connects an external meter, etc.

ANT SEL

When the [ANT] switch is ON:
13.8 V DC output 100 mA max.

Video equipment
Connects a video re-
corder, etc.

* No signals come out from [VIDEO OUT] for USA version.

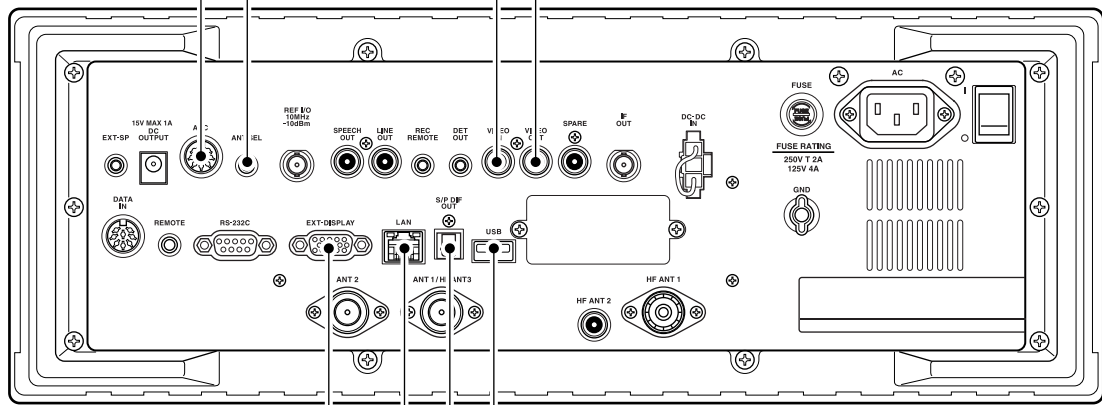

External Display

Connects a PC-style monitor display (at least 800×600 resolution). Video output signal can be turned ON and OFF in set mode (p. 11-9)

[S/P DIF IN/OUT]

Connects a PC for audio signal data (48 kHz, 16-bit) output.

[USB]

Connects a USB equipment such as memory, hub or keyboard.

Ethernet connector (p. 15-6)

Connects a PC via a LAN for CPU firmware update.

For Ferrite bead installation (example: LAN cable)

LAN socket

■ Tape recorder connections

The [REC REMOTE] jack is grounded when a signal is received and squelch opens. If a tape recorder has a control terminal, this jack can be used for recording control. (2 A/DC max.)

The [REC OUT] or [LINE OUT] jack has 350 mV rms/4.7 kΩ output for connection to other audio equipment.

◇ Recording from the front panel or rear panel

The [REC REMOTE] jack is grounded when a signal is received and squelch opens. If a tape recorder has a control terminal, this jack can be used for recording control. (2 A/DC max.)

The [REC OUT] or [LINE OUT] jack has 350 mV rms/4.7 kΩ output for connection to other audio equipment.

• Recording from the front panel

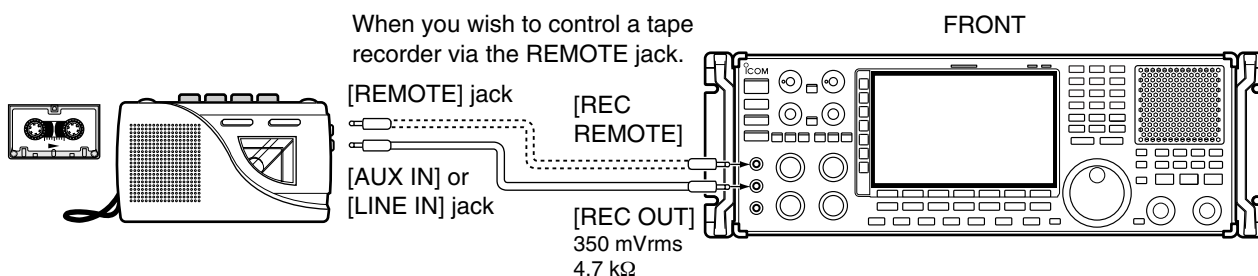

• Recording from the rear panel

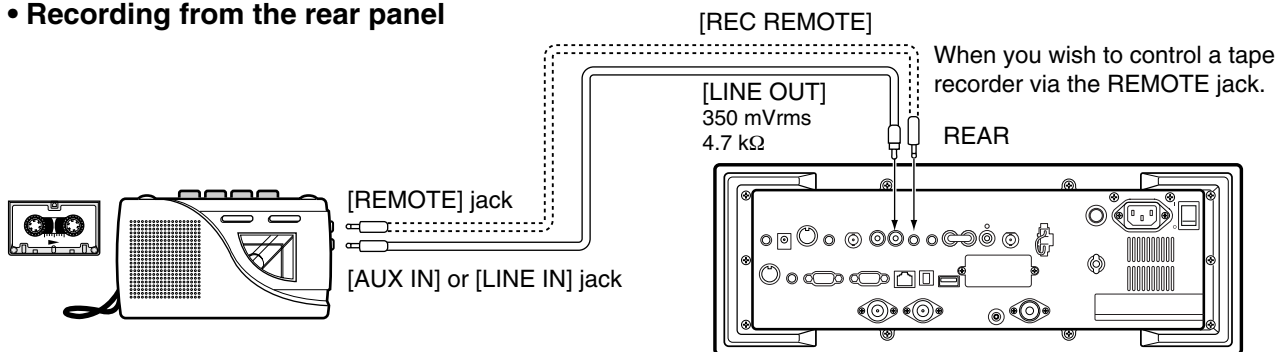

◇ Separately recording audio and frequency

When using a stereo tape recorder for recording, received audio and a frequency with a synthesized voice can be separately recorded.

When recording this way, you can search ahead of the audio signal recorded in the tape recorder using the frequency recording channel search.

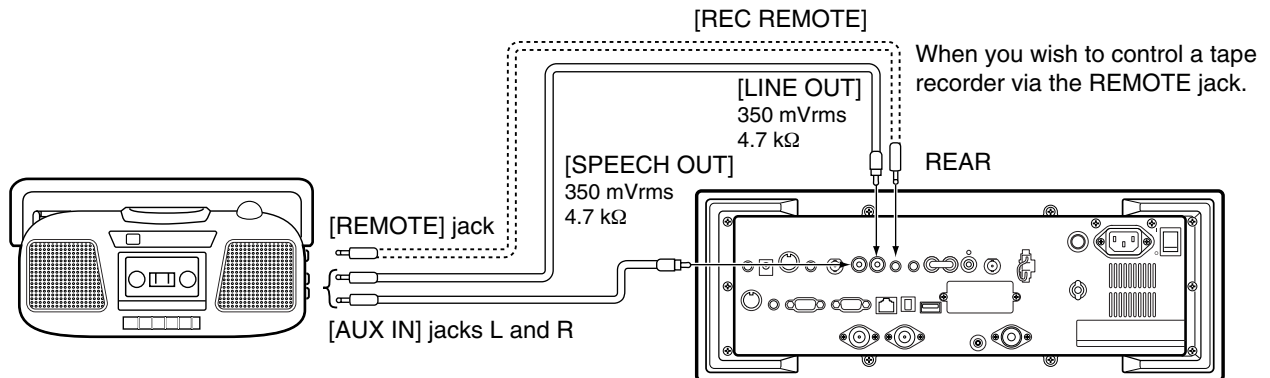

- Be sure the "REC SPEECH" item is turned ON, and "SPEECH Mix" item is select OFF in the others set mode (p. 11-11).

■ Monitor display connection

A monitor display can be connected to the IC-R9500 via the [DATA IN] socket and [EXT-DISPLAY]. You can monitor the LCD monitor information on a large size display.

The IC-R9500 includes a picture signal decoder. When connecting a TV set equipped with a VIDEO IN jack, you can monitor TV signals such as amateur TV.

NOTE: Video output from [DATA IN] is available as NTSC system only.

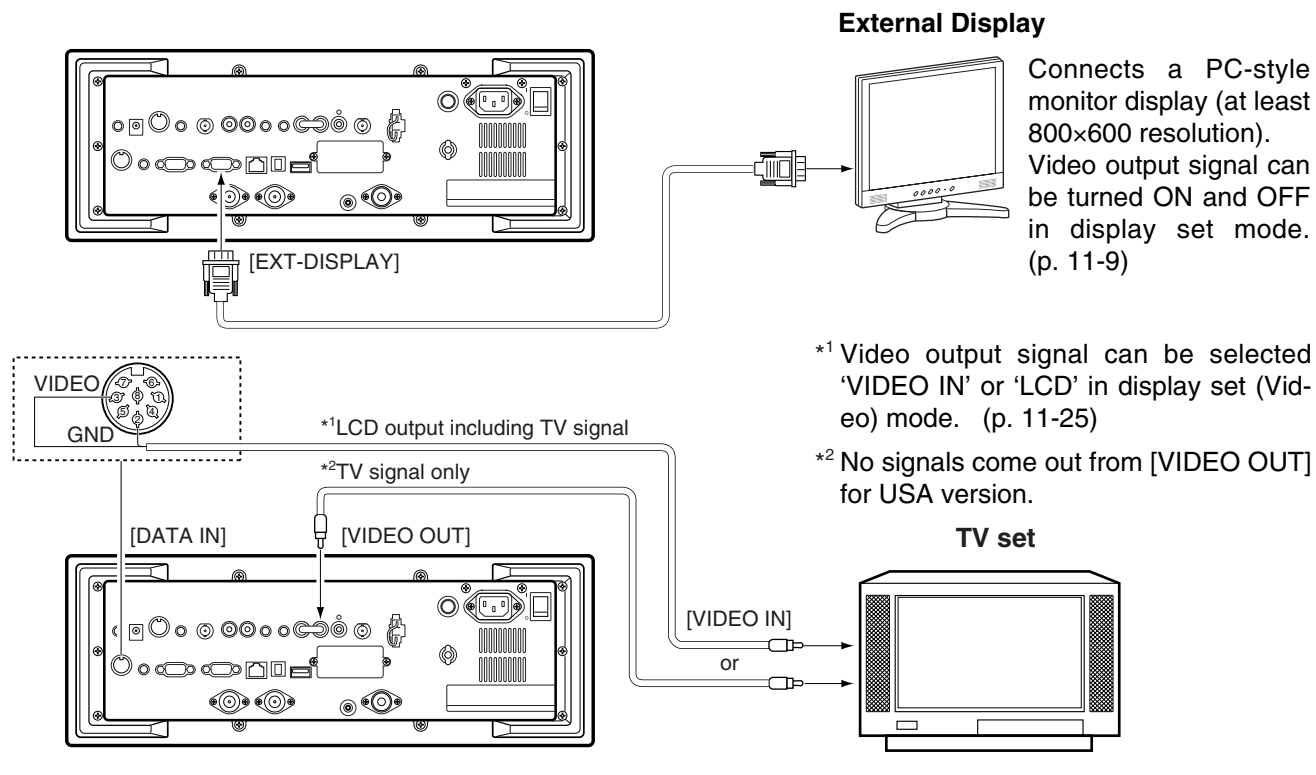

■ Transceive function

Icom CI-V transceivers or receivers can be connected via the [REMOTE] jack. The frequency and mode settings will follow* when either radio is changed.

* When a set frequency is out-of-range for one of the connected transceivers or receivers, the connected radio's frequency/mode does not change.

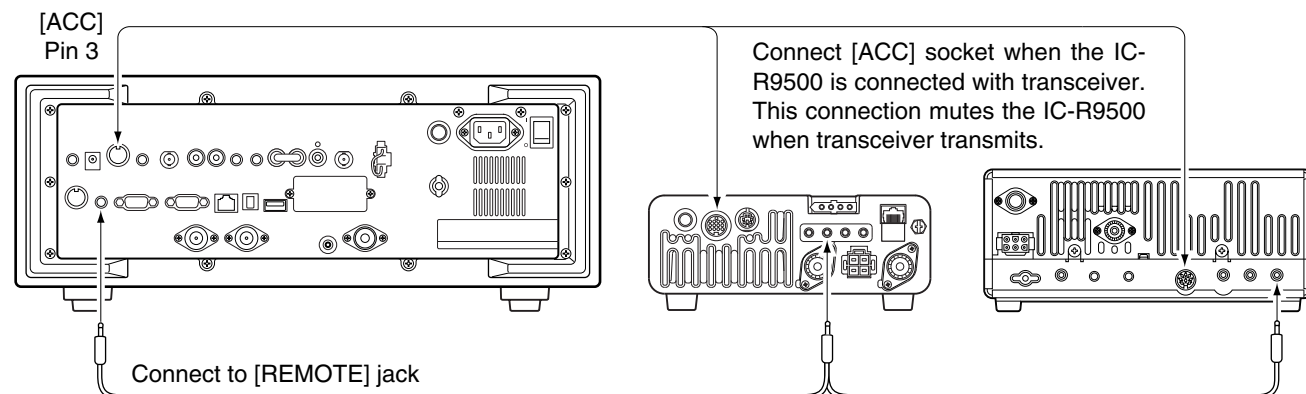

• Be sure the "CI-V Transceive" item is turned ON in the others set mode (p. 11-14).

■ FSK and AFSK (SSTV) connections

To connect a terminal unit, TNC or scan converter, refer to the diagram below.

- ① Connect a terminal unit as below.
- ② Select FSK mode (or USB, CW modes for HF band data communications).
- ③ Set the receiver to the desired frequency as shown to the right.
- ④ Set the connected terminal unit to the appropriate settings.
 - Refer to the terminal unit's instructions.

/// The narrow filter settings may not pass FSK signals. Be sure to select the appropriate IF filters corresponding to the signal width. (p. 5-12)

• **Frequency settings depend on the mode used.**

FM mode:

$$[\text{Setting frequency (displayed freq.)}] = [\text{Desired freq.}]$$

USB mode:

$$[\text{Setting frequency (displayed freq.)}] = [\text{Desired freq.}] - [\text{Center of Mark and Space freq.}]$$

CW narrow mode:

$$[\text{Setting frequency (displayed freq.)}] = [\text{Desired freq.}] - [\text{Center of Mark and Space freq.}] + [600 \text{ Hz}]$$

LSB mode (for amateur RTTY):

$$[\text{Setting frequency (displayed freq.)}] = [\text{Desired freq.}] + [\text{Mark freq.}]$$

• **When using a PC application**

Rear panel view

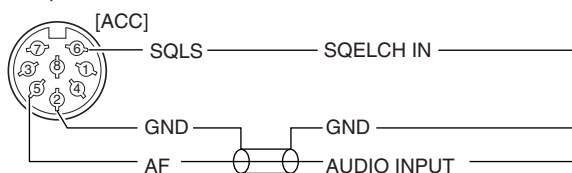

Connect to serial port, parallel port, speaker jack, and line IN/OUT jack, etc. See the instruction manual of the application for details.

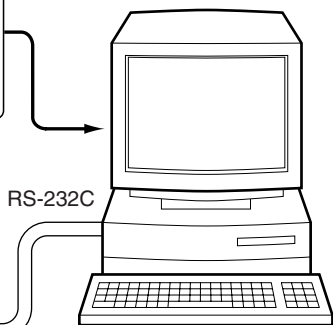

• **When using a TNC**

Rear panel view

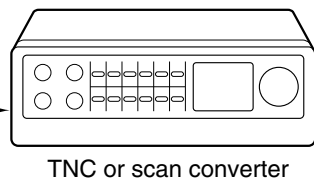
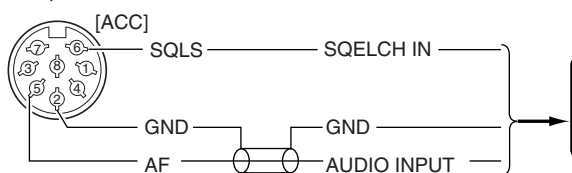

RS-232C

Personal computer

■ Accessory connector information

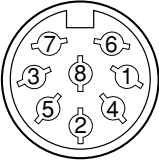
ACC	PIN No.	NAME	DESCRIPTION	SPECIFICATIONS
	1	ANTS	Outputs 5 V when the [ANTENNA] switch is ON.	Output current : Less than 100 μ A Output impedance : 10 k Ω
	2	GND	Connects to ground.	
	3	SEND	When grounded, attenuator activates and then audio is muted.	GROUND level : -0.5 to +0.8 V Input current : Less than 20 mA
	4	NC	No connection	
	5	AF	AF detector output. Fixed, regardless of [AF] position in default settings. (see notes below)	Output impedance : 47 k Ω Output level : 100–300 mV rms
	6	SQLS	Squelch output. Goes to ground when squelch opens.	Squelch open : Less than 0.3 V/5 mA Squelch closed : More than 6.0 V/100 μ A
	7	13.8 V	13.8 V output when power is ON.	Output current : 100 mA
	8	MOUT	Output S-meter level.	Output voltage : 0 to approx. 4 V Output impedance : 10 k Ω

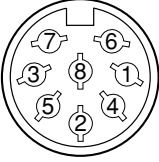
DATA IN	PIN No.	NAME	DESCRIPTION	SPECIFICATIONS
	1	DATA IN	—	
	2	GND	Connects to video ground.	
	3	VIDEO	Video signal output. (NTSC system only)	Output level : 1 V p-p \pm 0.2 V Output impedance : 75 Ω
	4	GND	—	
	5	NC	No connection	
	6	DATA OUT	—	
	7, 8	NC	No connection	

NOTE: If the beep level limit is in use, the beep tone decreases from the fixed level when the [AF] control is rotated above a specified level. (p. 11-6)