

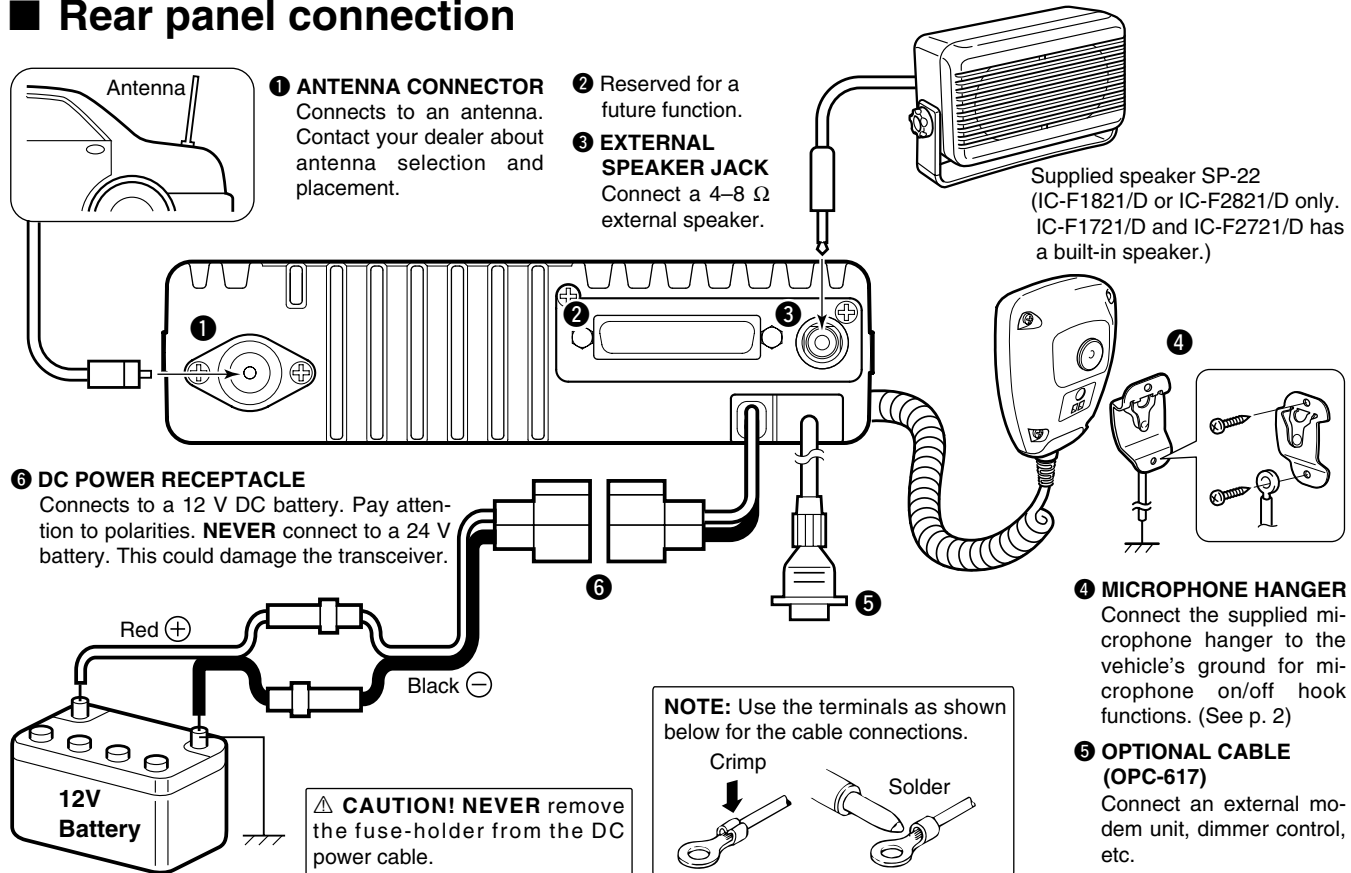

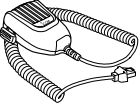







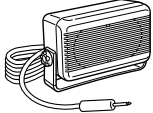
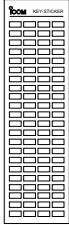
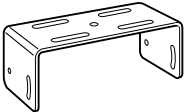

## ■ Rear panel connection



## ■ Supplied Accessories

<p>Microphone</p> 	<p>Microphone hanger and screw set</p> 	<p>Microphone hanger cable</p> 
<p>DC power cable</p> 	<p>Speaker*</p> 	<p>Function name stickers</p> 
<p>Mounting bracket</p> 	<p>Key cap</p> 	<p>Flat washers</p> 
	<p>Spring washers</p> 	<p>Bracket bolts</p> 
	<p>Nuts</p> 	<p>Mounting screws (M5×12)</p> 
		<p>Self-tapping screws (M5×16)</p> 

\*Depending on version

### • Function name stickers

There are no names on the programmable function keys since the functions can be freely assigned to these keys. Attach the supplied function name stickers as below to the appropriate keys for easy recognition of that key's assigned function.

Then, protect the attached stickers from unsticking with the supplied key cap as below.

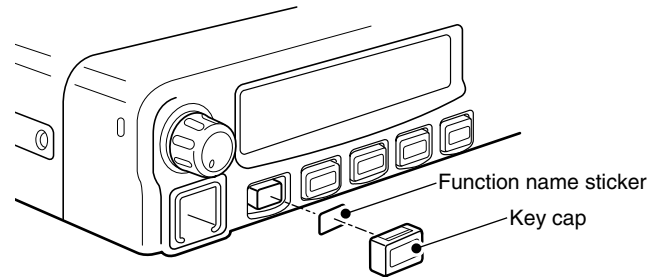

## 4 CONNECTION AND MAINTENANCE

### ■ Mounting the transceiver

The universal mounting bracket supplied with your transceiver allows overhead mounting.

- Mount the transceiver securely with the 4 supplied screws to a thick surface which can support more than 1.5 kg.

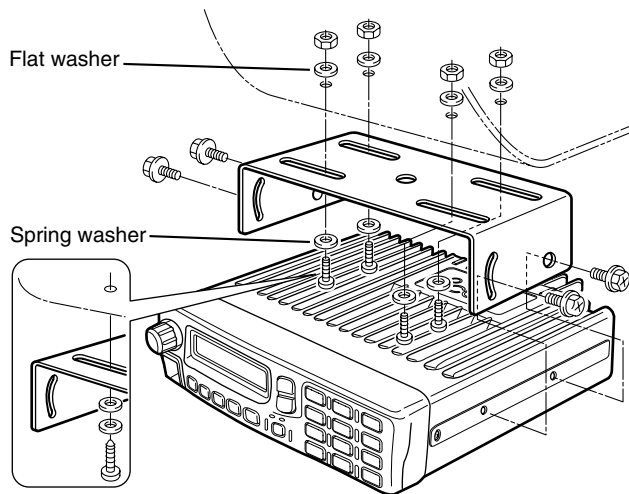

When using self-tapping screws

### ■ Optional UT-111 installation

Install the optional UT-111 unit as follows:

- ① Turn the power OFF, then disconnect the DC power cable.
- ② Unscrew the 4 cover screws, then remove the bottom cover.
- ③ Cut the pattern on the PCB at the CP57, then solder CP58 as shown below.
- ④ Install the unit as shown in the diagram below.
- ⑤ Replace the bottom cover and screws, then re-connect the DC power cable.

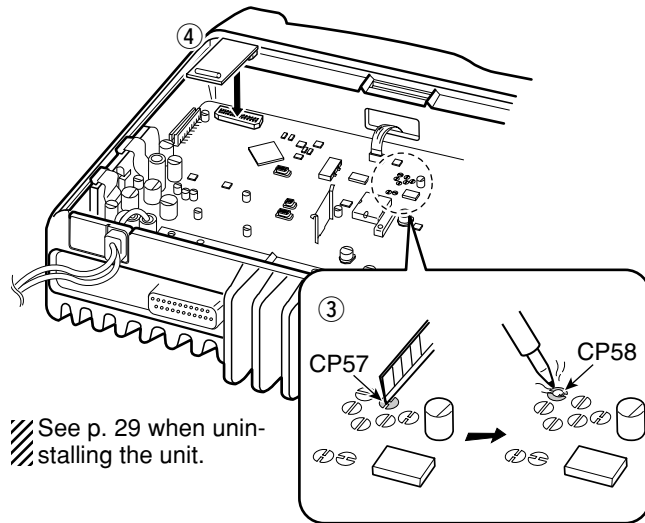

## Optional UT-109 or UT-110 installation

- ① Turn the power OFF, then disconnect the DC power cable.
- ② Unscrew the 4 cover screws, then remove the bottom cover.
- ③ Cut the pattern on the PCB at the TX mic circuit (MIC) and RX AF circuit (AF OUT), then solder CP37 as shown below.
- ④ Install the scrambler unit as described in the installation of optional UT-111 installation on p. 28
- ⑤ Replace the bottom cover and screws.

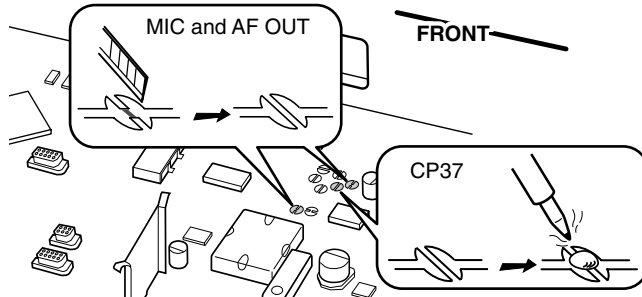

**NOTE: When uninstalling the unit**

Be sure to re-solder the disconnected points and un-solder the connected points as above when you remove the unit. Otherwise no TX modulation or AF output is available.

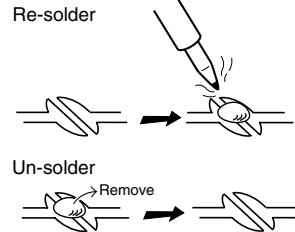

## Optional OPC-617 installation

Install the OPC-617 as shown below.

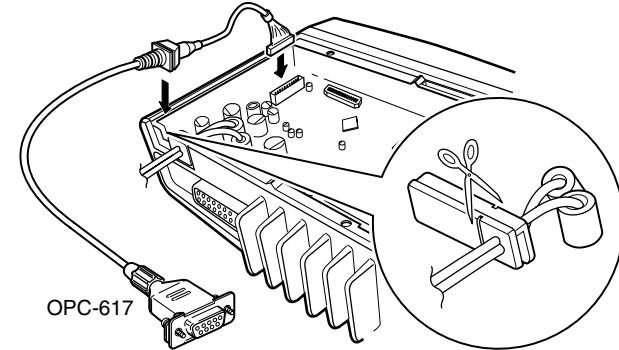

Cut off the bushing as in the illustration, when you install the optional OPC-617.

### OPTIONAL CABLE PIN ASSIGNMENT

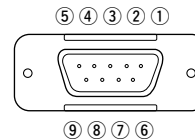

- |  |                        |
|--|------------------------|
| ① Dimmer cont. IN                      | ⑥ Horn drive cont. OUT |
| ② AF OUT                               | ⑦ AF GND               |
| ③ Det. AF OUT                          | ⑧ Det. AF GND          |
| ④ Mod. IN                              | ⑨ Mod. GND             |
| ⑤ PTT control IN or<br>FTSW control IN |                        |

## 4 CONNECTION AND MAINTENANCE

### ■ Antenna

A key element in the performance of any communication system is an antenna. Contact your dealer about antennas and the best places to mount them.

### ■ Fuse replacement

A fuse is installed in the supplied DC power cable. If a fuse blows or the transceiver stops functioning, track down the source of the problem if possible, and replace the damaged fuse with a new rated one.

□ Fuse rating: 20 A

**USE** the 20 A fuse only.

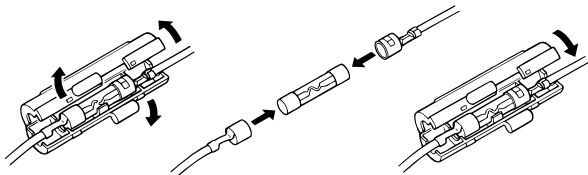

### ■ Cleaning

If the transceiver becomes dusty or dirty, wipe it clean with a soft, dry cloth.



**AVOID** the use of solvents such as benzene or alcohol, as they may damage the transceiver surfaces.

### ■ Options

- **RMK-2** SEPARATION KIT + **OPC-607/OPC-608/OPC-609** SEPARATION CABLE  
Allows you to install the transceiver main unit separately from the front panel for operating convenience.
- **SP-5/SP-22** EXTERNAL SPEAKER  
Input impedance : 4  $\Omega$   
Max. input power : 5 W  
SP-5 : Large speaker for good audio quality.  
SP-22 : Compact and easy-to-install. The same as supplied with the transceiver (depending on version.)
- **HM-152/HM-152T/HM-148** HAND MICROPHONE  
HM-152 : Hand microphone  
HM-152T : DTMF microphone  
HM-148 : Heavy duty microphone
- **SM-25** DESKTOP MICROPHONE
- **UT-109 (#02)/UT-110 (#02)** SCRAMBLER UNITS  
Non-rolling type (UT-109)/Rolling type (UT-110) voice scrambler unit provides higher communication security.
- **UT-111** LTR TRUNKING BOARD  
Provides trunking operation.
- **OPC-617** ACC CABLE  
Allows you to connect to an external terminal.