

- Unpacking ..... 2-2
- Antenna jumper cable connection ..... 2-2
- Selecting a location ..... 2-2
- Rack mounting handle attachment ..... 2-2
- Grounding ..... 2-3
- Antenna connection ..... 2-3
- CF (Compact Flash) memory card ..... 2-3
- Required connections ..... 2-4
  - ◇ Front panel ..... 2-4
  - ◇ Rear panel ..... 2-4
- Advanced connections ..... 2-5
  - ◇ Front panel ..... 2-5
  - ◇ Rear panel—1 ..... 2-5
  - ◇ Rear panel—2 ..... 2-6
- Linear amplifier connections ..... 2-7
  - ◇ Connecting the IC-PW1 ..... 2-7
  - ◇ Connecting a non-Icom linear amplifier ..... 2-7
- Transverter jack information ..... 2-8
- FSK and AFSK (SSTV) connections ..... 2-8
- Microphone connector information ..... 2-9
- Microphones (options) ..... 2-9
  - ◇ SM-20 ..... 2-9
  - ◇ HM-36 ..... 2-9
- Accessory connector information ..... 2-10

 **CAUTION!:** The transceiver weighs approx. 25 kg (55 lb). Always have two people available to carry, lift or turn over the transceiver.

## ■ Unpacking

After unpacking, immediately report any damage to the delivering carrier or dealer. Keep the shipping cartons.

For a description and a diagram of accessory equipment included with the IC-7800, see 'Supplied accessories' on p. iii of this manual.

## ■ Antenna jumper cable connection

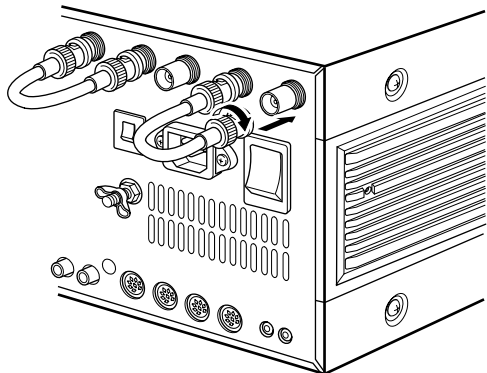

Connect the supplied coaxial cable (terminated with BNC connectors) between [RX ANT A— IN] and [RX ANT A— OUT], and, [RX ANT B— IN] and [RX ANT B— OUT], respectively.

When connecting an external filter unit, pre-amplifier, etc., connect the unit between [RX ANT A/B— IN] and [RX ANT A/B— OUT] connectors.

## ■ Selecting a location

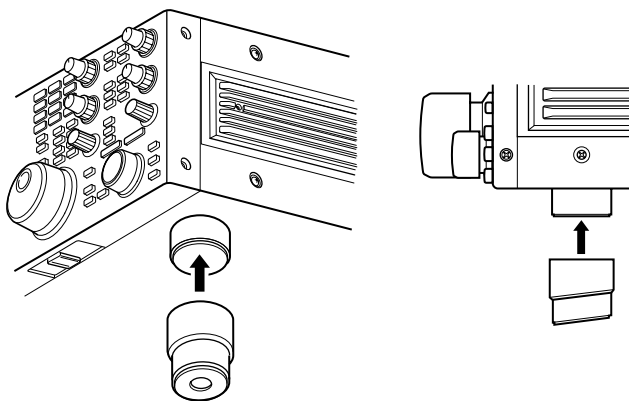

Select a location for the transceiver that allows adequate air circulation, free from extreme heat, cold, or vibrations, and away from TV sets, TV antenna elements, radios and other electromagnetic sources.

The base of the transceiver has an adjustable stand for desktop use. Set the stand to one of two angles depending on your operating preference.

## ■ Rack mounting handle attachment

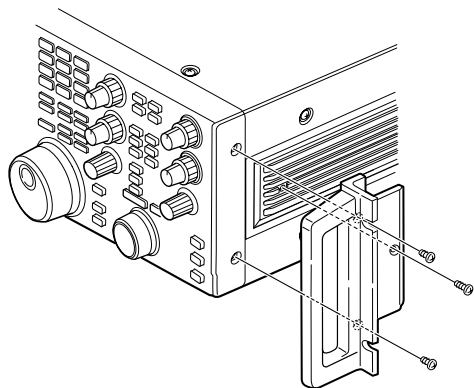

Remove the four screws from both sides of the front panel and the two screws from both sides of the side panel, then attach the rack mounting handles to the sides of the transceiver using the supplied screws.

## ■ Grounding

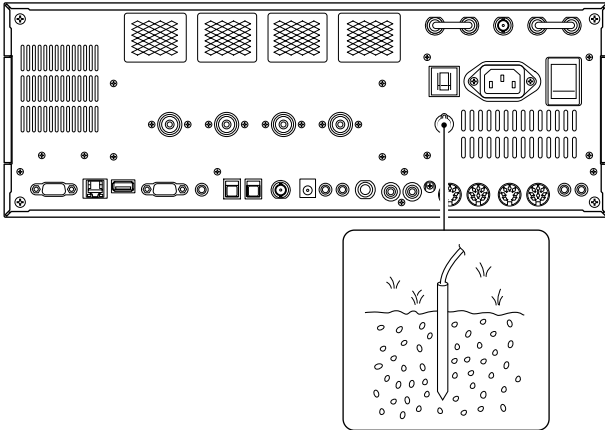

To prevent electrical shock, television interference (TVI), broadcast interference (BCI) and other problems, ground the transceiver through the GROUND terminal on the rear panel.

For best results, connect a heavy gauge wire or strap to a long earth-sunk copper rod. Make the distance between the [GND] terminal and ground as short as possible.

**⚠ WARNING: NEVER** connect the [GND] terminal to a gas or electric pipe, since the connection could cause an explosion or electric shock.

## ■ Antenna connection

**PL-259 CONNECTOR INSTALLATION EXAMPLE**

- ① Slide the coupling ring down. Strip the cable jacket and soft solder.
- ② Strip the cable as shown at left. Soft solder the center conductor.
- ③ Slide the connector body on and solder it.
- ④ Screw the coupling ring onto the connector body.

30 mm ≈ 9/8 in    10 mm ≈ 3/8 in    1-2 mm ≈ 1/16 in

For radio communications, the antenna is of critical importance, along with output power and receiver sensitivity. Select antenna(s), such as a well-matched 50 Ω antenna, and feedline. We recommend 1.5:1 or better of Voltage Standing Wave Ratio (VSWR) for your desired band. Of course, the transmission line should be a coaxial cable.

When using 1 antenna, use the [ANT1] connector.

**⚠ CAUTION:** Protect your transceiver from lightning by using a lightning arrestor.

### Antenna SWR

Each antenna is tuned for a specified frequency range and SWR may be increased out-of-range. When the SWR is higher than approx. 2.0:1, the transceiver's power drops to protect the final transistors. In this case, an antenna tuner is useful to match the transceiver and antenna. Low SWR allows full power for transmitting. The IC-7800 has an SWR meter to monitor the antenna SWR continuously.

## ■ CF (Compact Flash) memory card

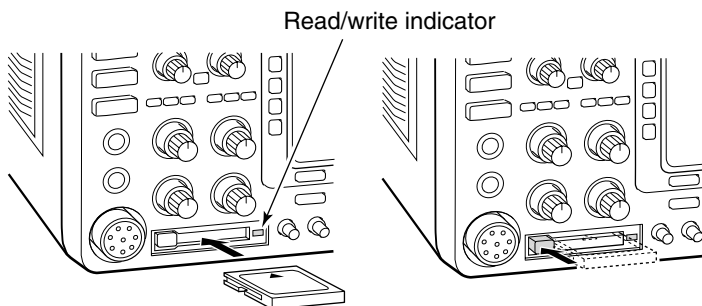

Insert the supplied CF (Compact Flash) memory card into the CF memory card slot.

- To remove the CF memory card, push-in the button, located at left hand side of the slot.

**⚠** Make sure to install the memory card correctly. **NEVER** insert or remove the CF memory card when the read/write indicator lights or blinks.

## Required connections

### Front panel

#### CW key

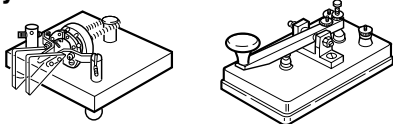

A straight or bug key can be used when the internal electronic keyer is turned OFF in keyer set mode. (p. 4-12)

#### Microphones (p. 2-9)



Optional SM-20

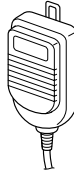

Optional HM-36

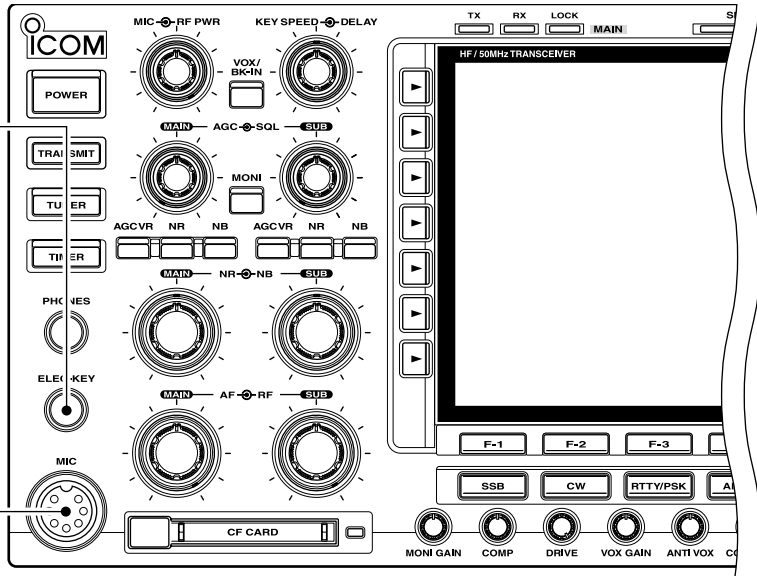

### Rear panel

#### Antenna 1, 2, 3, 4 (p. 2-3)

[Example]: ANT1 for 1.8–18 MHz bands, ANT 2 for 21–28 bands  
ANT3 for 50 MHz band, ANT 4 for receive antenna.

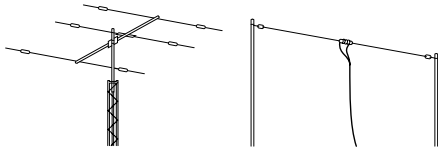

**NOTE:** Attach the supplied antenna connector cap when no antenna or external equipment is connected.

A jumper cable is connected.

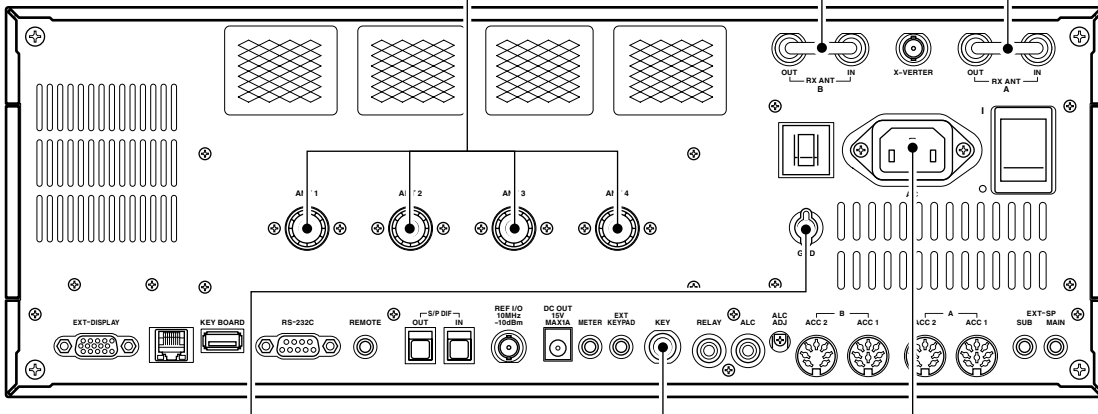

#### Ground (p. 2-3)

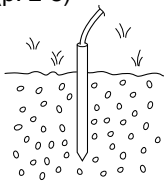

Use the heaviest gauge wire or strap available and make the connection as short as possible.

Grounding prevents electrical shocks, TVI and other problems.

#### Straight key

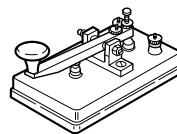

#### AC outlet

**WARNING:**  
Use the supplied AC power cable only.

## Advanced connections

### Front panel

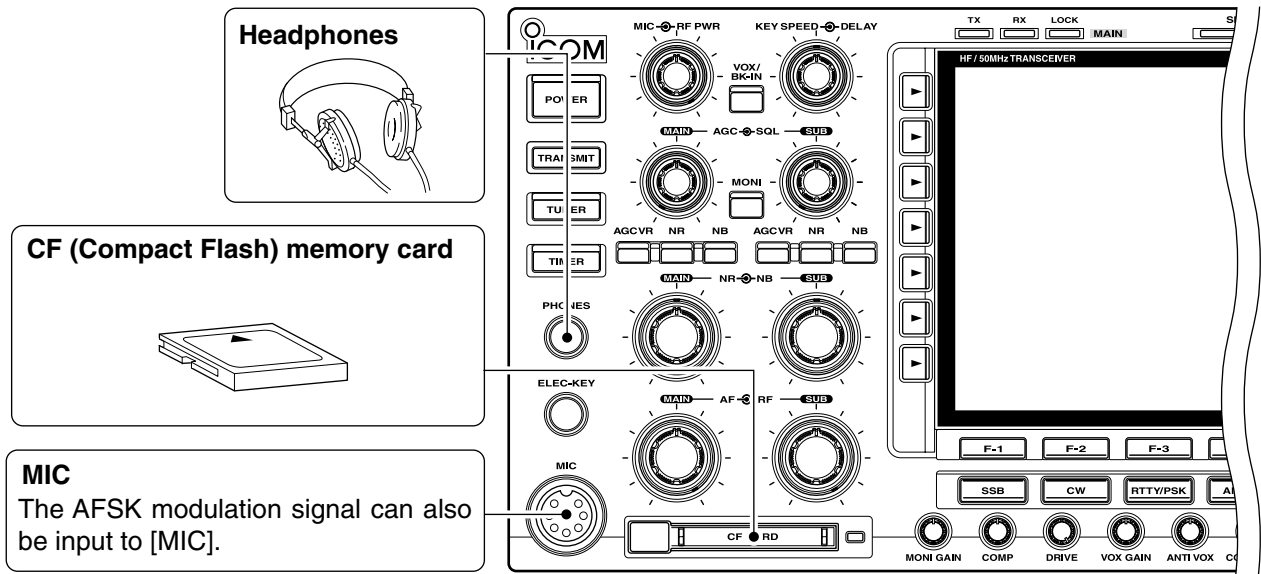

### Rear panel— 1

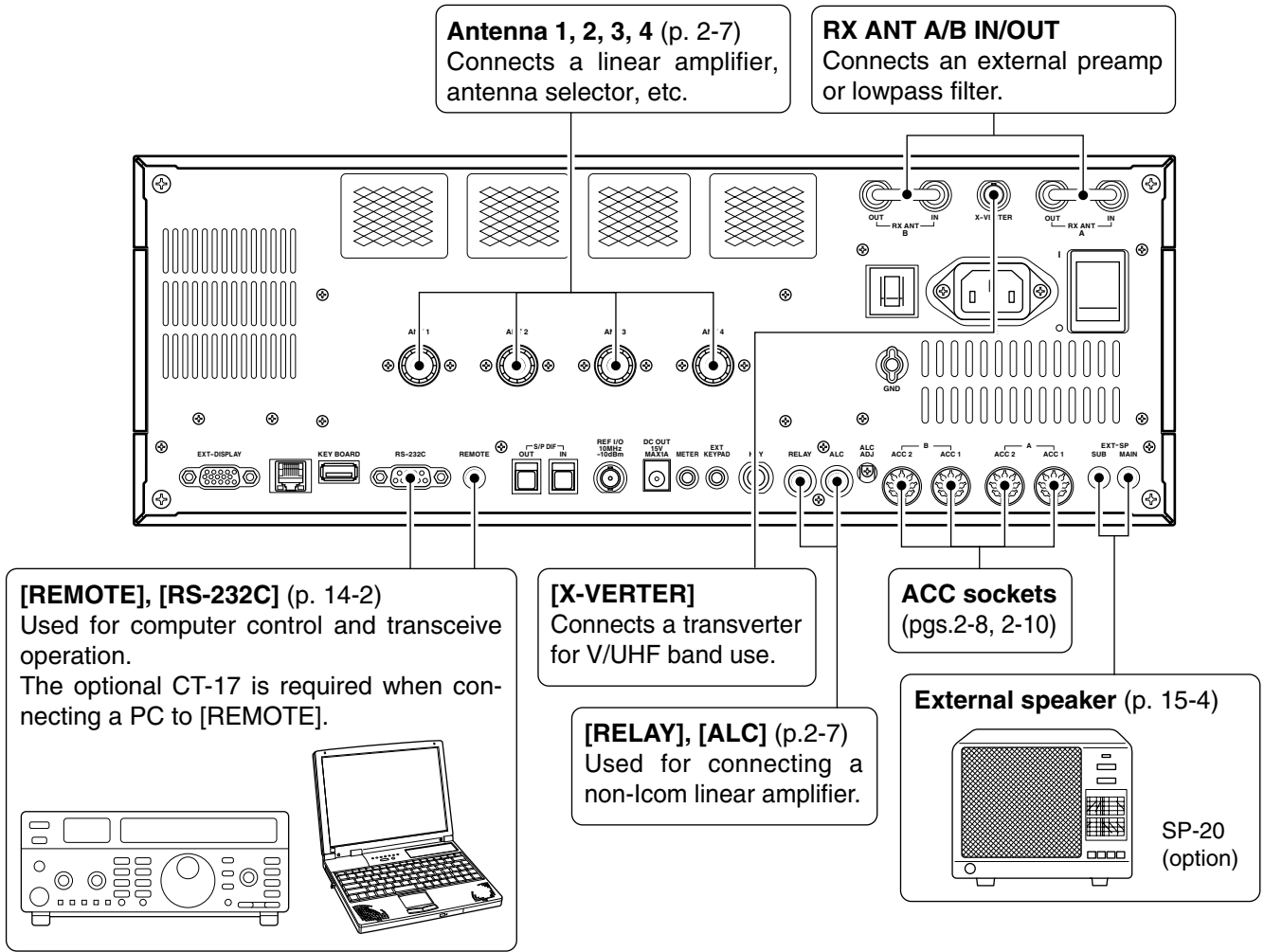

◇ Rear panel— 2

**External Display**

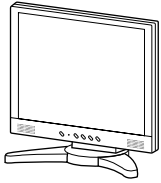

Connects a PC-style monitor display (at least 800×600 resolution). Video output signal can be turned ON and OFF in set mode (p. 12-12)

**Keyboard**

Connects an USB type PC keyboard directly for RTTY/PSK31 operation, as well as other text edit operations.



**[DC OUT]**

Outputs regulated 14 V (approx.) DC for external equipment power supply. (max. 1 A capacity)

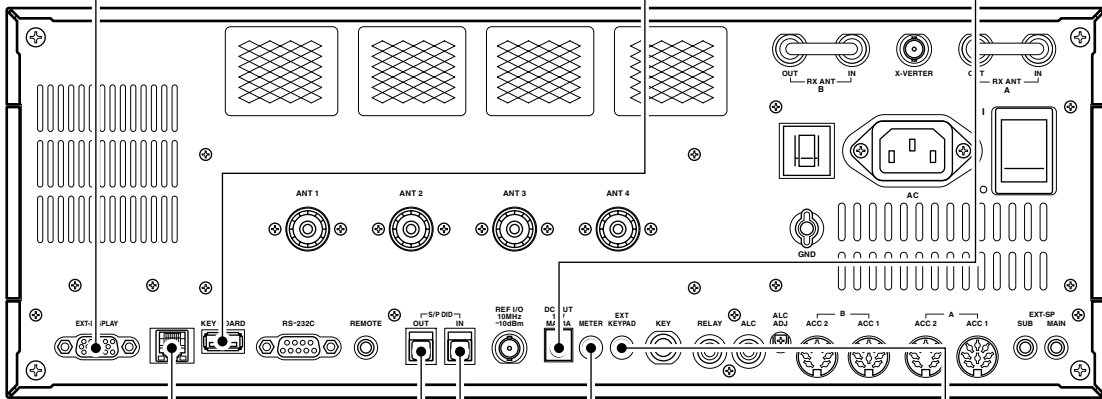

**Ethernet connector (p. 16-6)**



Connects a PC via a LAN for the CPU firmware update.

**[METER]**

Connects an external meter, etc.

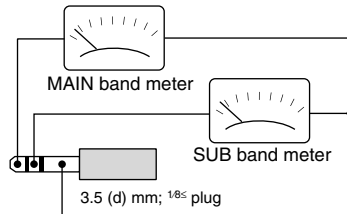

**[S/P DEAF IN/OUT]**



Connects a PC for audio signal data input/output.  
48 kHz, 16-bit Stereo output (L=Main band; R=Sub band)

**External keypad**

Connects an external keypad for direct voice memory and memory keyer controls.

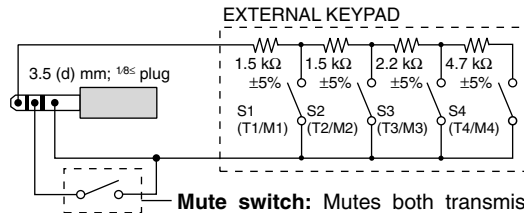

**Mute switch:** Mutes both transmission and reception when switched ON during transceive operation, etc.

## Linear amplifier connections

### Connecting the IC-PW1/EURO

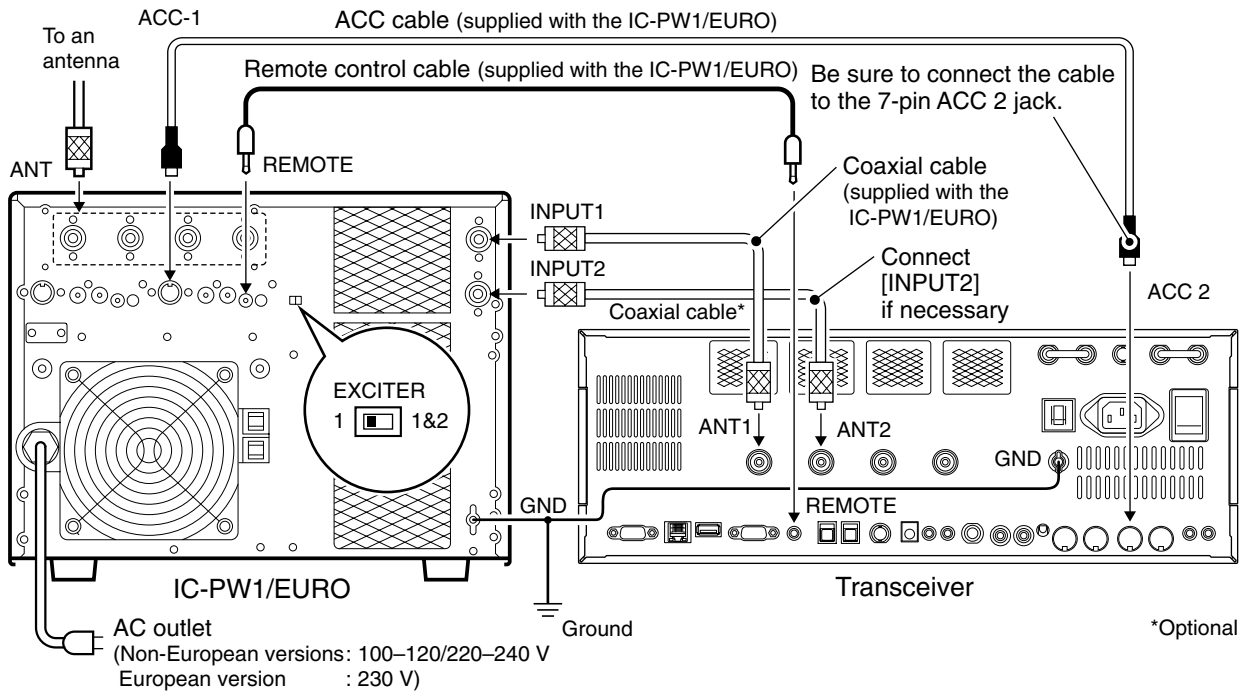

### Connecting a non-Icom linear amplifier

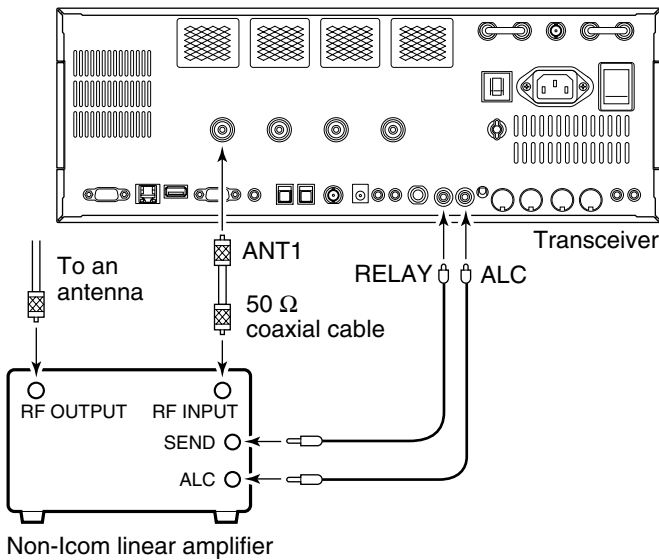

#### ⚠ WARNING:

Set the transceiver output power and linear amplifier ALC output level referring to the linear amplifier instruction manual.

The ALC input level must be in the range 0 V to -4 V, and the transceiver does not accept positive voltage. Non-matched ALC and RF power settings could cause a fire or ruin the linear amplifier.

The maximum control level of [RELAY] jack is 16 V/0.5 A DC with initial setting, and 250 V/200 mA with "MOS-FET" setting (see p. 12-9 for details). Use an external relay unit when your non-Icom linear amplifier requires control voltage and/or current greater than specified.

## ■ Transverter jack information

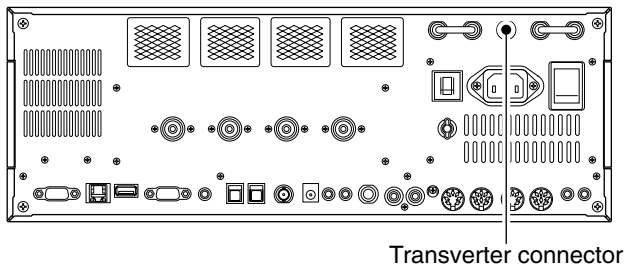

When 2 to 13.8 V is applied to pin 6 of [ACC 2], the [X-VERTER] connector is activated for transverter operation and the antenna connectors do not receive or transmit any signals. (p. 4-6)

While receiving, [X-VERTER] connector can be activated as an input terminal from an external transverter.

While transmitting, the [X-VERTER] connector outputs signals of the displayed frequency at  $-20$  dBm (22 mV) as signals for the external transverter.

## ■ FSK and AFSK (SSTV) connections

To connect a TNC or scan converter, etc., refer to the diagram below.

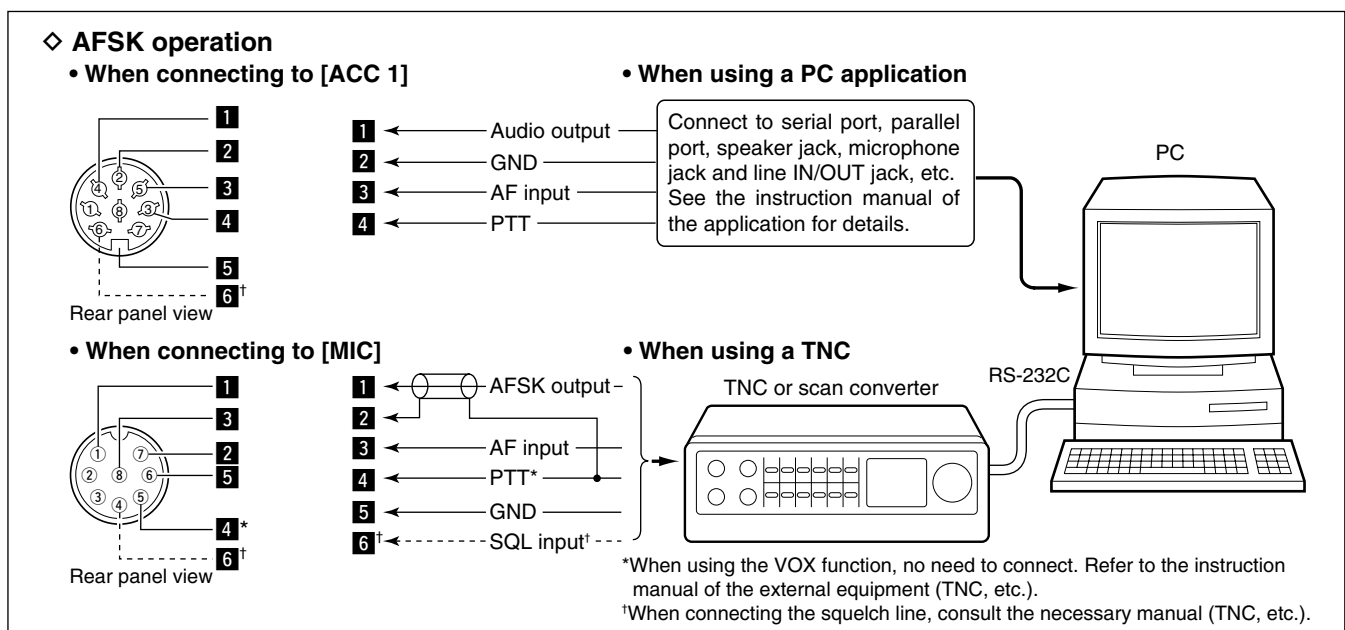
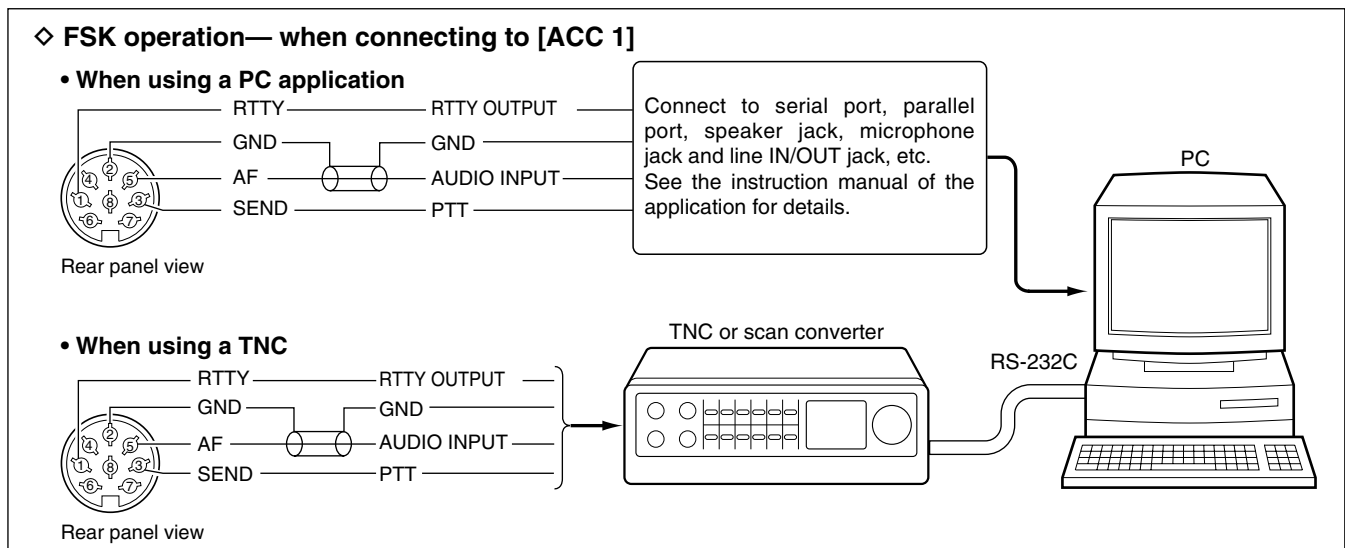

## Microphone connector information

(Front panel view)

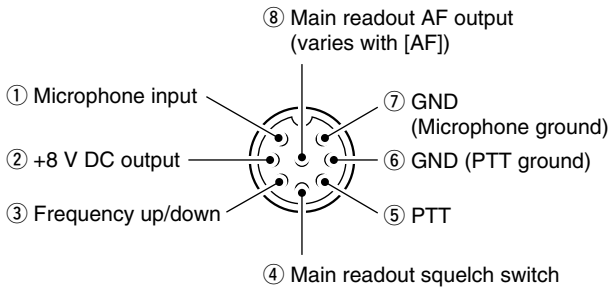

[MIC] Pin No.	FUNCTION	DESCRIPTION
②	+8 V DC output	Max. 10 mA
③	Frequency up	Ground
	Frequency down	Ground through 470 Ω
④	Squelch open	“Low” level
	Squelch closed	“High” level

**CAUTION:** DO NOT short pin 2 to ground as this can damage the internal 8 V regulator.  
**NOTE:** DC voltage is applied to pin 1 for microphone operation. Take care when using a non-lcom microphone.

## Microphones (options)

### ◇ SM-20

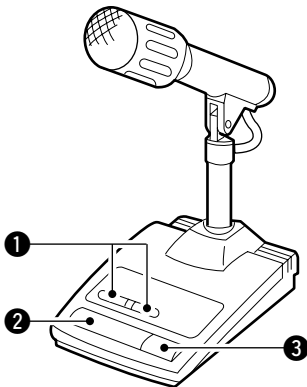

### ◇ HM-36

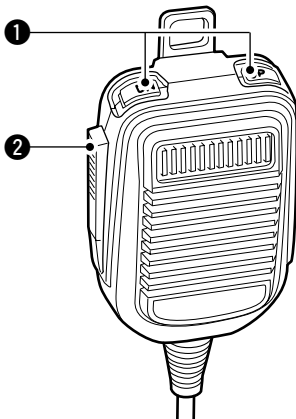

#### ① UP/DOWN SWITCHES [UP]/[DN]

Change the selected readout frequency or memory channel.

- Continuous pushing changes the frequency or memory channel number continuously.
- While pushing [XFC], the transmit readout frequency can be controlled while in split frequency operation.
- The [UP]/[DN] switch can simulate a key paddle. Preset in the keyer set mode. (p. 4-12)

#### ② PTT SWITCH

Push and hold to transmit; release to receive.

#### ③ PTT LOCK SWITCH (available for SM-20 only)

Push to toggle between transmit and receive.

### ■ Accessory connector information

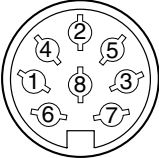
ACC 1	PIN No.	NAME	DESCRIPTION	SPECIFICATIONS
	1	RTTY	Controls RTTY keying	“High” level : More than 2.4 V “Low” level : Less than 0.6 V Output current : Less than 2 mA
	2	GND	Connects to ground.	Connected in parallel with ACC 2 pin 2.
	3	SEND	Input/output pin. Goes to ground when transmitting. When grounded, transmits.	Ground level : -0.5 V to 0.8 V Output current : Less than 20 mA Input current (Tx) : Less than 200 mA Connected in parallel with ACC 2 pin 3.
	4	MOD	Modulator input. Connects to a modulator.	Input impedance : 10 kΩ Input level : Approx. 100 mV rms
	5	AF	AF detector output. Fixed, regardless of [AF] position in default settings. (see notes below)	Output impedance : 4.7 kΩ Output level : 100–300 mV rms
	6	SQLS	Squelch output. Goes to ground when squelch opens.	SQL open : Less than 0.3 V/5 mA SQL closed : More than 6.0 V/100 μA
	7	13.8 V	13.8 V output when power is ON.	Output current : Max. 1 A Connected in parallel with ACC 2 pin 7.
	8	ALC	ALC voltage input.	Control voltage : -4 V to 0 V Input impedance : More than 10 kΩ Connected in parallel with ACC 2 pin 5.

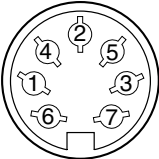
ACC 2	PIN No.	NAME	DESCRIPTION	SPECIFICATIONS
	1	8 V	Regulated 8 V output.	Output voltage : 8 V ±0.3 V Output current : Less than 10 mA
	2	GND	Same as ACC 1 pin 2.	
	3	SEND	Same as ACC 1 pin 3.	
	4	BAND	Band voltage output. (Varies with amateur band)	Output voltage : 0 to 8.0 V
	5	ALC	Same as ACC 1 pin 8.	
	6	TRV	Activates [X-VERTER] input/output when “HIGH” voltage is applied.	Input impedance : More than 10 kΩ Input voltage : 2 to 13.8 V
	7	13.8 V	Same as ACC 1 pin 7.	

**NOTE:** If the CW side tone level limit or beep level limit is in use, the CW side tone or beep tone decreases from the fixed level when the [AF] control is rotated above a specified level. (p. 12-5)